

# CajunKooling

Cool. Clean. Comfort.

## Evaporative Air Cooler User's Instruction Manual: Model CK3000

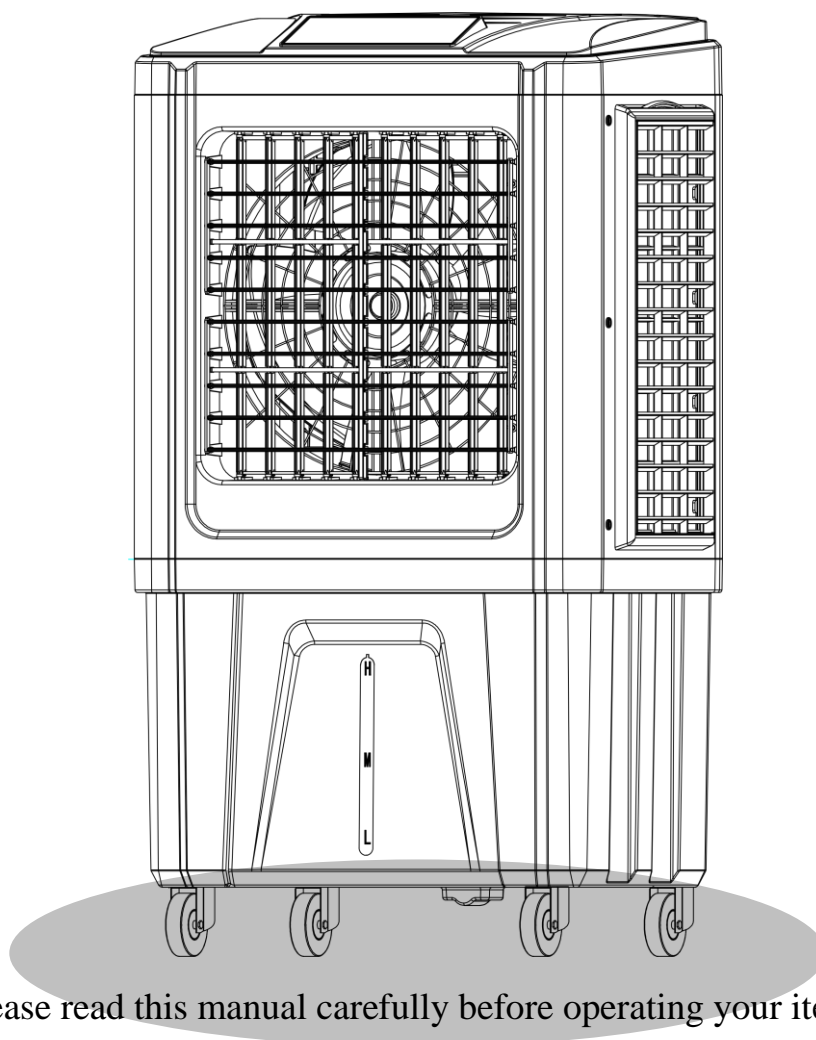

Please read this manual carefully before operating your items.

Retain it for future reference.

**CONTENTS**

Product Introduction -----3

Main Specifications -----4

Range of Application-----4

Structure Diagram-----5

Circuit Wiring Diagram -----6

Operation Instruction -----7

Installation Instruction-----8

Maintenance Instruction-----9

Troubleshooting-----10

Warranty: -----11

---

REMOVE ALL PACKING MATERIALS FROM THIS PRODUCT BEFORE USING IT. THIS APPLIANCE MUST BE INSTALLED ON A FLAT SURFACE. PLEASE ENSURE THE ELECTRIC SUPPLY TO THIS APPLIANCE IS DISCONNECTED BEFORE ANY MAINTENACE.

Please read this instruction carefully. It is advisable to keep this instruction manual in a safe place for future reference.

### ***I Product Introduction***

Cajun Kooling has evolved evaporative air coolers into a modern unit that features specially shaped fan blades for lower noise, an attached water reservoir, three intakes for more airflow and a smaller casing, and protective screens for the cooling pads. They also have the following advantages:

1. Energy-saving: Up to 80% or more when compared to traditional air-conditioners
2. Environment protection: No discharge of hazardous substances and foam free during its operation
3. Efficient: Achieving the maximum cooling and purifying effect with minimum power consumption
4. Easy to mobilize and maintain

Evaporative air coolers use the evaporation process for the production of cooler and cleaner air. The continuous water flow from the pump disperses water onto the media (cooling pads). The warm air passes through the intakes over the wet media, which is a honeycomb-type filter layer made of compressed cardboard material. The movement of the wind over the water creates the process of evaporation, giving you cooler and cleaner air.

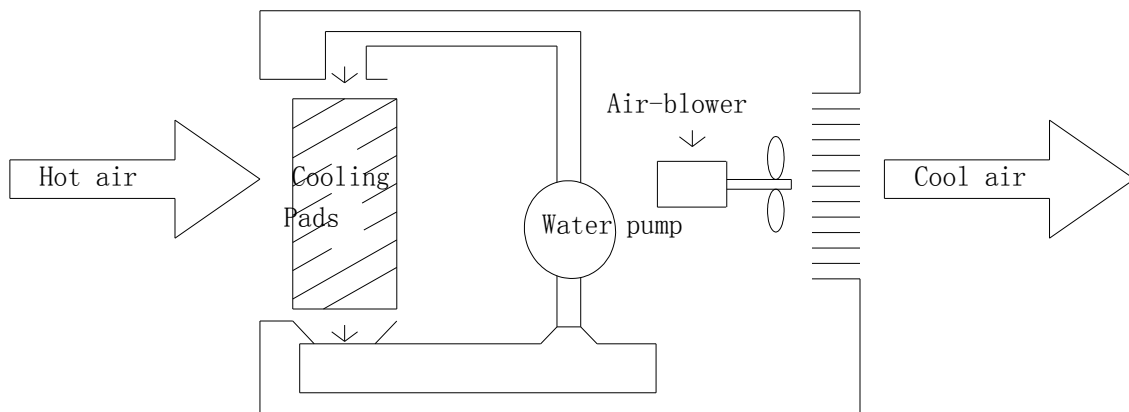

Principle Diagram

## ***II Main Specifications***

Voltage/Frequency	100~110 V/60 Hz
Working Current	1.7 Amp
Water Consumption	1~2 L/h
Noise	60dB
Max Air Volume	3000CFM
Power	190W
Water Storage	16G
Packing size (mm)	27*17*44 INCH
Weight	46lbS
Fan Type	Axial Fan

## ***III Applications***

Evaporative air coolers serve several purposes for areas including: air circulation, cooling, and air purification. This product is useful for many areas including:

- Patios, restaurants, tailgating, garages and docks
- Kennels, barns, and greenhouses
- Industrial warehouses, shops, and energy plants
- Construction sites
- Venues

## *IV Structure Diagram*

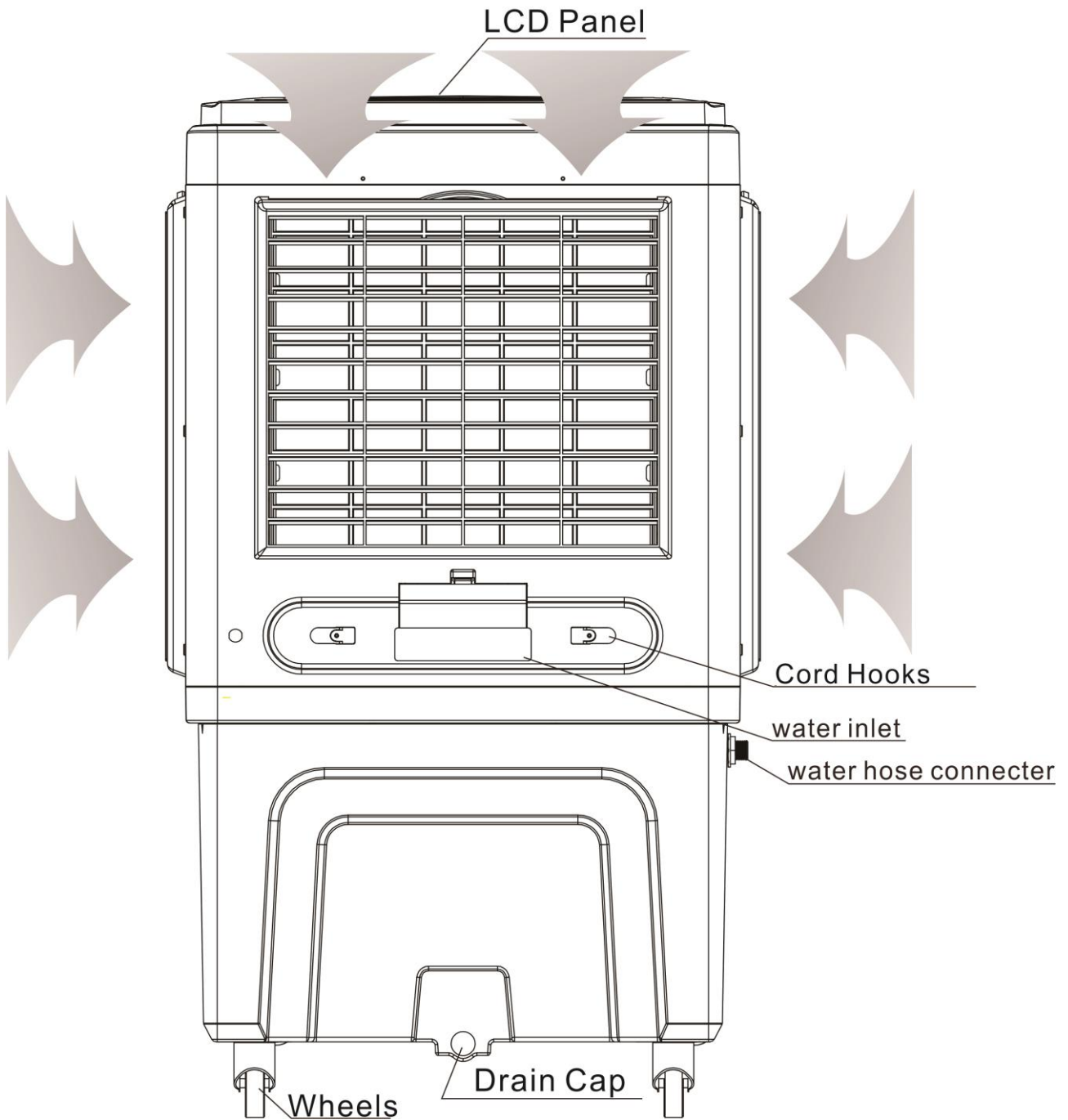

## V Circuit Wiring Diagram

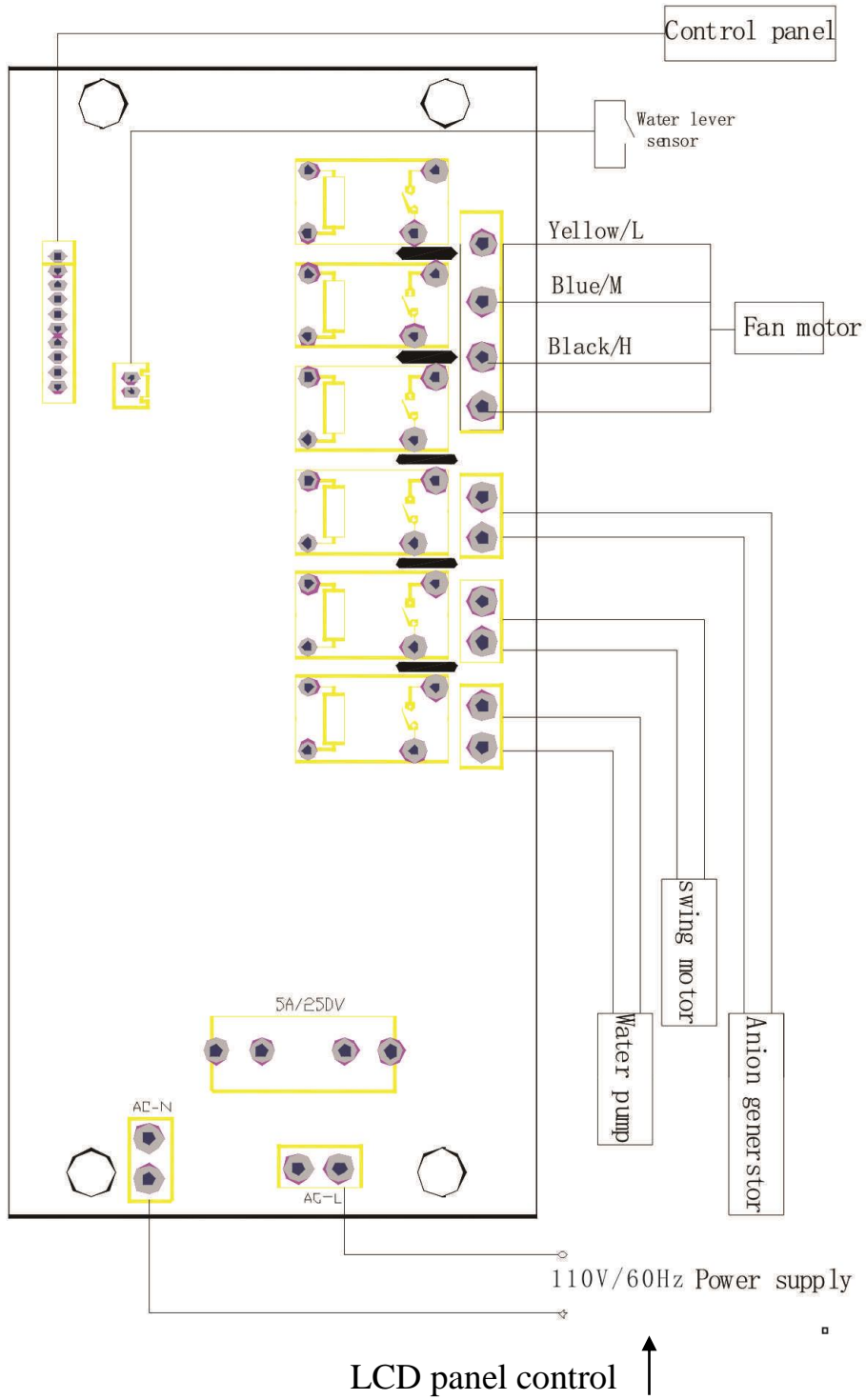

## ***VI Operation Instruction***

**Operation of LCD control panel& remote controller, as following:**

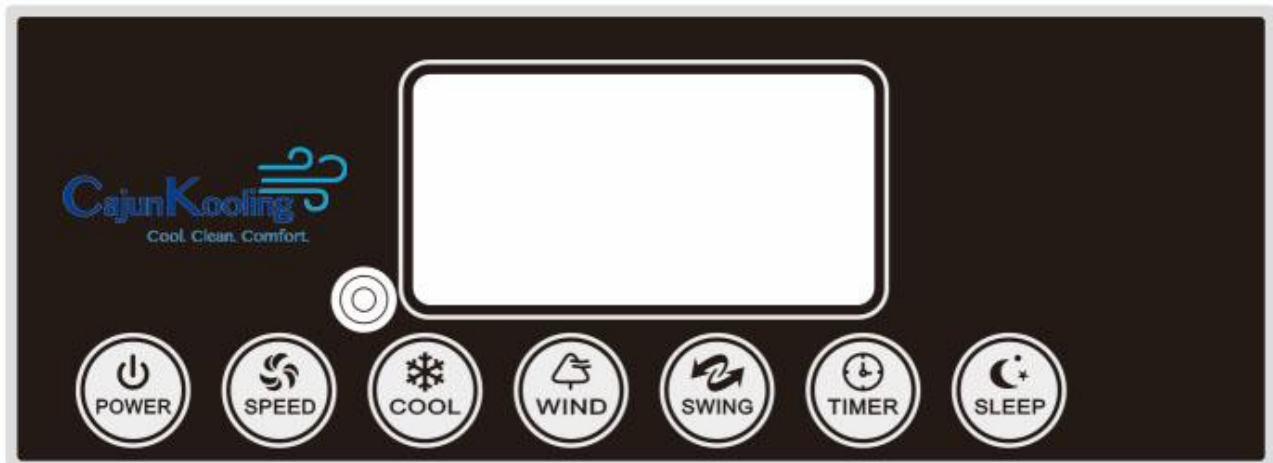

**After plugging to a 110V/60Hz power outlet, it will be on stand-by mode with a buzzer ringing.**

### **1. Power**

Pressing the power on will automatically turn on the cooling (water pump)

### **2. Cool**

Press this button to turn ON the pump, the fan will shut down and restart after 30 seconds

### **3. Wind**

Press this button to run as a fan only. This feature will turn the pump OFF

### **4. Speed**

Press this button to adjust the fan speed between high, medium and low

### **5. Swing**

Press this button for automatic oscillation mode, swinging the vertical blades left to right

### **6. Sleep**

**(Recommended) This option will dry the cooling pads before shut down**

Press this button for self-drying timer. The pump will shutdown immediately, then will automatically start shutting down in speed intervals of 30 minutes

### **7. Timer**

Use to adjust the timing of complete shutdown. Time ranging from 1 to 12 hours

### **\* Note:**

- ✓ When pressing the button every time, a buzzer will ring. The operations of remote control is the same as the control panel
- ✓ When the water level is below the warning level, the water pump will stop working and buzzer will send an alert. The pump will return to work after water is added

## ***VIII Installation Instructions***

**1. Open the package and take out the air cooler. Inspect for any damage to the unit.**

**2. To add water, open the water inlet in the back and put the water into the water tank. The water level in the front of the unit will show how much water is filled**

- The water must be below the maximum level (-), otherwise the water will overflow or splash from the fan blades
- Use clean water to fill up the air cooler (tap water will suffice)
- Refer to the tips sheet on [www.cajunkooling.com](http://www.cajunkooling.com) for additional care and maintenance instructions

### **3. Warning**

- Always operate the product from a power source of the same voltage, frequency and rating as indicated on the product identification sticker (silver sticker)
- Do not operate this product if it has malfunctioned, damaged cord or plug or appears damaged in any way. Return the complete product to the place of purchase for inspection, repair or replacement.
- This product should not be used in the immediate vicinity of water, such as bathtub, sinks, etc. where the likelihood of immersion or splashing could occur.
- This product can't be directly placed under the rain.
- Always switch off and unplug the plug from outlet when not in use, before assembling or disassembling parts and before cleaning. Fully assemble the air cooler before operating.
- Do not insert any objects through the fan blades when the air cooler is operating.
- After adding water, do not tilt, collide, lay or move the machine to any position that will make the water overflow.
- Allow an 8-inch space around the air intakes to allow enough air flow
- Clean the screens with a wet cloth or rinse with water hose
- If the machine is not in use, pull the power plug out



## ***VIII Maintenance Instruction***

Turn the power off before maintenance or repair of the machine to prevent accidents. To ensure the cooling effect of the machine, the machine body should be wiped by clean cloth. The interior of the machine shall be also cleaned regularly, and the proper cleaning interval is once a month. However, the actual cleaning time will vary depending on the exterior environment and frequency of usage. Refer to [www.cajunkooling.com](http://www.cajunkooling.com) for more cleaning and care instructions

### **1. Instructions for cleaning the interior of the air cooler:**

- 1) Drain the tank of any unused water
- 2) Rinse the tank out with new water then drain again. Turn the fan to wind mode only and allow the cooling pads and interiors to dry for 30 minutes. The interior should be completely dry before storing for long periods of time to prevent mold.

Attention: during cleaning, the pressure of the water should not be too strong. When cleaning the cooling pads, do not use any acidic or corrosive detergents.

## ***IX Troubleshooting***

<b>Troubles</b>	<b>Common causes</b>	<b>Solutions</b>
Unable to start the fan	Power failure	Check power supply
	Switch burned	Inspect and repair the appliances. (only by authorized service center)
No air flow	Motor starter's capacitor damaged	Inspect and repair the appliances. (only by authorized service center)
	Motor damaged	Inspect and repair the appliances. (only by authorized service center)
	The cooling pad is clogged with dust	Rinse off the cooling pads
Airflow not cool	No water in tank or "cooling function" not on	Add water
	Water pump damaged	Inspect and repair the appliances. (only by authorized service center)
	Cooling pad is dirty	Clean the cooling pad
Unpleasant odor	Water or cooling pad is dirty	Change the water and clean cooling pad. Dry out pads after use to prevent

**Attention!**

The following is important information regarding your warranty. Please read before opening and operating your unit.

*Warranty*

Welcome to your new evaporative air cooler. After purchasing this product, please fill out the form below, and mail it to the Cajun Kooling. address within 14 days of purchase. This will ensure you a one-year warranty on all mechanical parts, not including labor. Please check items upon opening to make sure that all parts are properly working, in order to validate your warranty. Please cut on dotted line and mail into the Cajun Kooling .address. Your mailed in warranty will be validated according to the date on our copy of your receipt from purchase.

Cajun Kooling

112 Thruway Park

Broussard, LA 70518

1-844-819-3557



Customer Name: \_\_\_\_\_

Tel. Number: \_\_\_\_\_

**Model Type: (Circle One)**

-CK3000 \_\_\_\_\_

Customer Address: \_\_\_\_\_

Date and Location Purchased: \_\_\_\_\_

**Serial Number:**

(listed on silver sticker on side of unit: ex. Ck300000170500000)

---